



MOTEUR NR25 (1600-2200W)

PLAGE DE PUISSANCE 1600-2200W
POWER RANGE 1600-2200W

Pression d'utilisation 6 bars
Pressure of use 6 bars

Consommation d'air maxi : 2950 l/min.
Air consumption: 2950 l/min.

NR25 (2200)	Vitesse à puissance maxi (rpm) Speed at Max power (rpm)	Vitesse à vide (rpm) Free speed (rpm)	Couple à Pmax. N.m Pmax Torque N.m	Couple au calage N.m Stall torque N.m	A (mm)	Poids (kg) Weight (kg)
		639	1594	33	65	425
	533	1331	40	78	425	5,3
	418	1044	50	99	425	5,3
	292	729	72	142	456	5,7
	133	332	158	312	456	5,7
	111	277	190	374	456	5,7

D'autres vitesses et couples sont disponibles, nous consulter
For additional speed and torque, please contact our sales department

Sens de rotation Rotation		Vitesse à puissance maxi Speed at max power	Echappement Exhaust	
Rotation à droite Right turn	RT	Exemple : 292 RPM	Filtre Filter	F
Rotation à gauche Left turn	LT	Autres vitesses voir tableau page ci-contre More rotary speed, please refer to the table		
Reversible Reversible	RV			

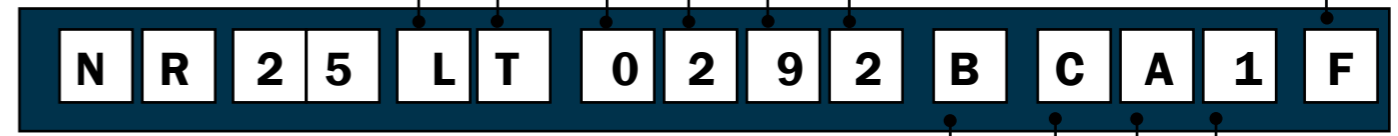

Type de bride (voir page 4)
Flange type (refer to page 4)

Type de sortie (voir page 4)
Shaft type (refer to page 4)

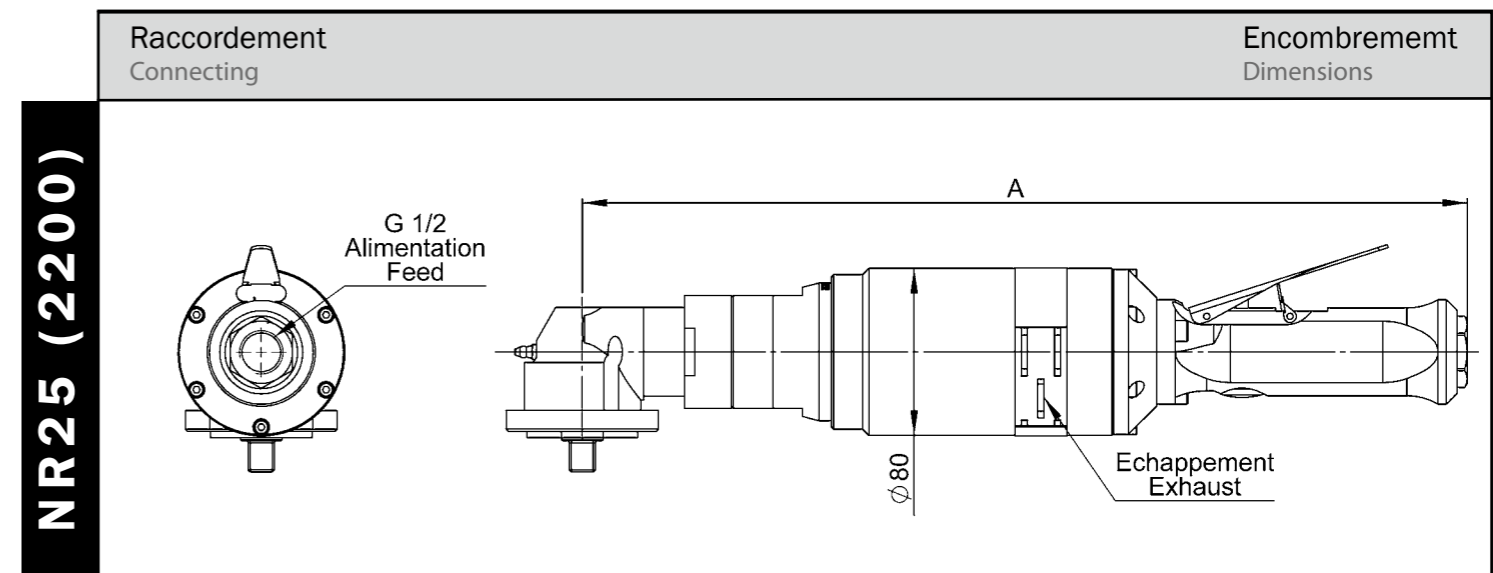
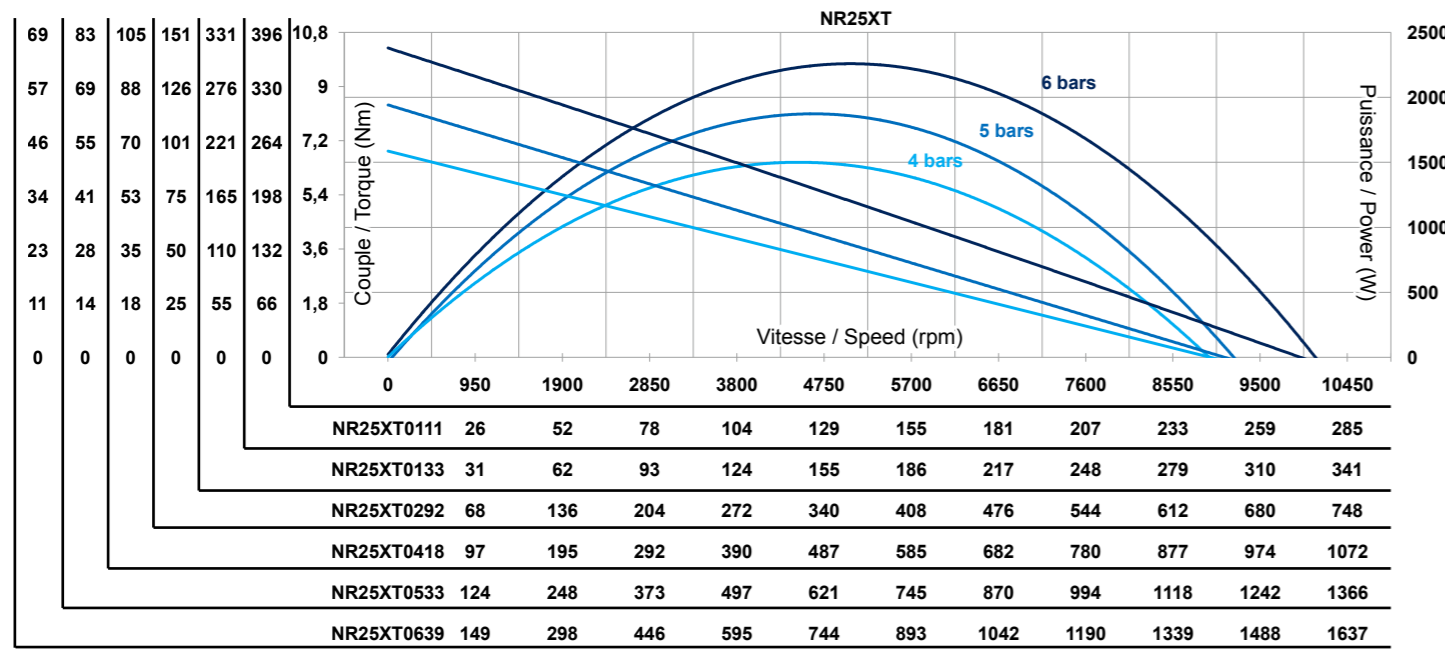

	Kv mini distributeur Kv mini distributor	Diamètre mini raccord Mini fitting diameter	Diamètre mini tuyau Mini pipe diameter	Lubrification Lubrication
Europe	60 Kv	11 mm	20 mm	8,1 gouttes / min
US	4,2 Cv	0,4334 in	0,788 in	8,1 drops / min

Valeurs indiquées pour des longueurs ne dépassant pas 5 mètres de flexible, au-delà il faut utiliser un diamètre de flexible plus important.
These recommendation are only valuable for hose lengths inferior to 5 meters. Beyond 5 meters, a larger size of hose diameter has to be used.



Tableau de conversion / Conversion table		
Watt → Horse power	Newton mètre → Foot-pound	Millimètre → Inch
Watt x 0,001341 = hp	Nm x 0,7376 = ib.-ft.	mm x 0,03937 = in
Bar → Pound per square inch	N Litre/minute → Standard cubic per minute	Kilogramme → Pound
Bar x 14,5 = PSI	L/min x 0,03531 = scfm	Kg x 2,205 = ib

Type de bride : NR-08-25

Flange type

Type B : bride de montage 3 trous
3 holes mounting flange (B type)

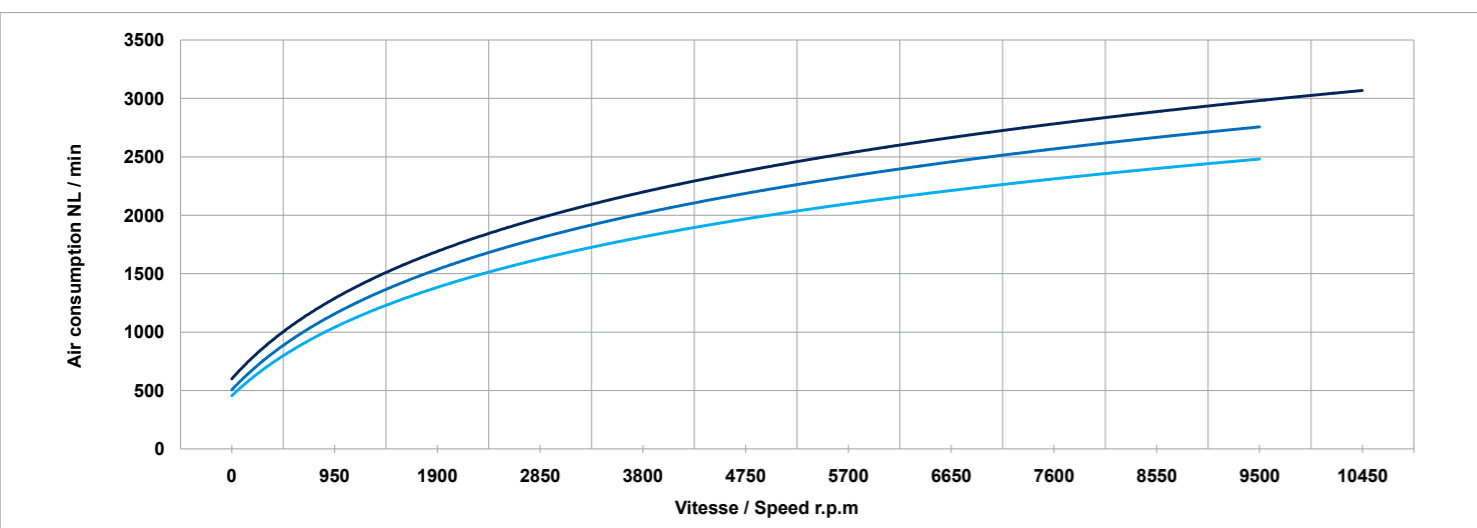
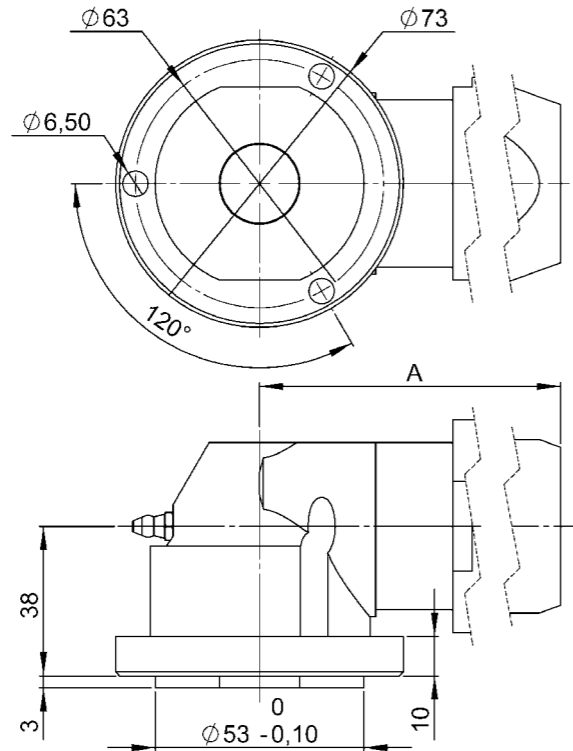

Type de sortie : NR-08-25

Shaft type

Type CA1 : Sortie carrée
CA1 type : square drive

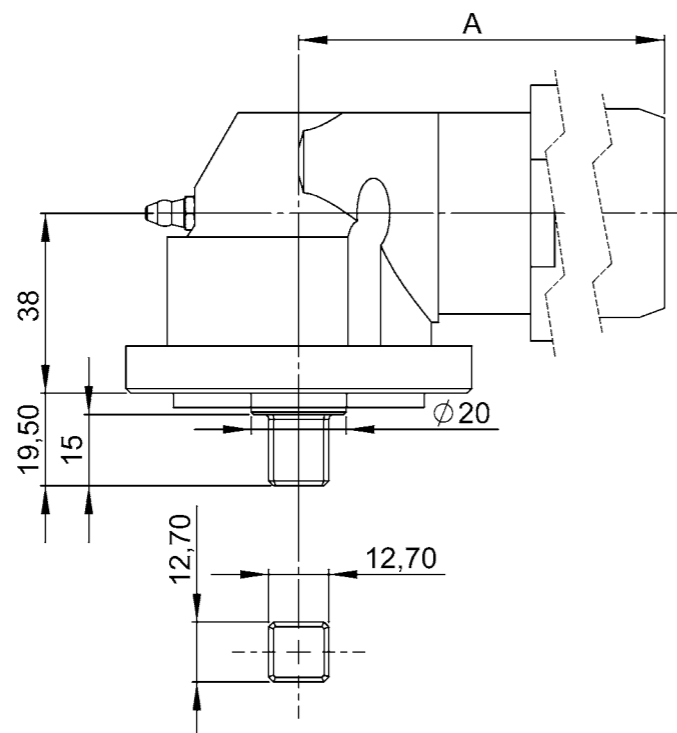

Type CL2 : sortie clavetée

CL2 type : Square key

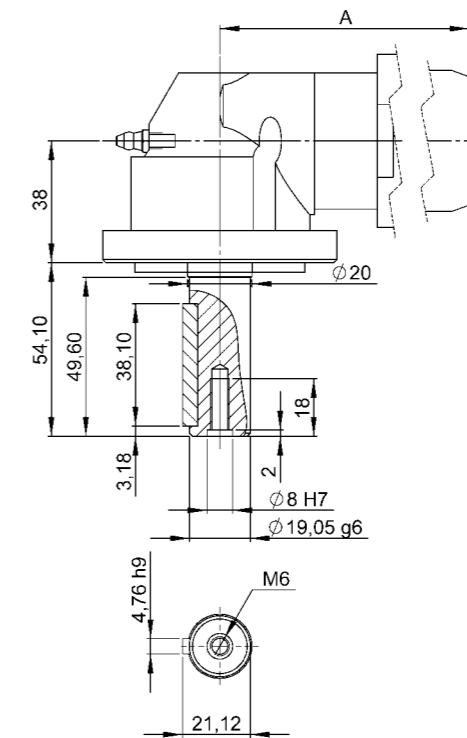

Type FI1 : Sortie filetée

FI1 type : threaded shaft

